

Akce 2025

# VarioTool



**WEXO®**  
KOMPETENZ IN PRÄZISION

Strojní závitníky



M
Typ N
ISO 2 6H
HSSE
60° P
DIN 13

M

HSSE

SELECT/TAP by WEXO®

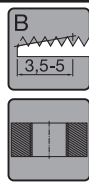
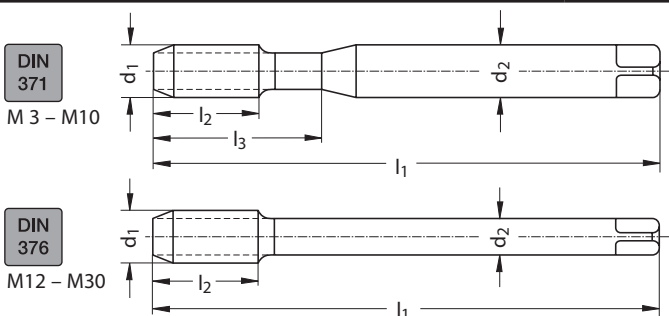

Rozměry										NB00			NB00VP			NB00TI		
d <sub>1</sub>	P	l <sub>1</sub>	l <sub>2</sub>	l <sub>3</sub>	d <sub>2</sub>	□	z	∅	Obj. číslo	Kč Set*	Kč Set*	Obj. číslo	Kč Set*	Kč Set*	Obj. číslo	Kč Set*	Kč Set*	
M 3	0,5	56	9	18	3,5	2,7	3	2,5	GAV 600 000	<del>-2 550</del>	1 430	GAV 601 000	<del>-2 550</del>	1 430	GAV 602 000	<del>-4 400</del>	2 470	
M 4	0,7	63	12	21	4,5	3,4	3	3,3	GAV 600 002	<del>-2 550</del>	1 430	GAV 601 002	<del>-2 550</del>	1 430	GAV 602 002	<del>-4 400</del>	2 470	
M 5	0,8	70	13	25	6	4,9	3	4,2	GAV 600 003	<del>-2 680</del>	1 500	GAV 601 003	<del>-2 680</del>	1 500	GAV 602 003	<del>-4 530</del>	2 540	
M 6	1	80	15	30	6	4,9	3	5	GAV 600 004	<del>-2 680</del>	1 500	GAV 601 004	<del>-2 680</del>	1 500	GAV 602 004	<del>-4 530</del>	2 540	
M 8	1,25	90	18	35	8	6,2	3	6,8	GAV 600 006	<del>-3 510</del>	1 970	GAV 601 006	<del>-3 510</del>	1 970	GAV 602 006	<del>-5 675</del>	3 180	
M 10	1,5	100	20	39	10	8	3	8,5	GAV 600 008	<del>-4 145</del>	2 330	GAV 601 008	<del>-4 145</del>	2 330	GAV 602 008	<del>-7 140</del>	4 000	
M 12	1,75	110	23	0	9	7	3	10,2	GAV 600 010	<del>-5 550</del>	3 110	GAV 601 010	<del>-5 550</del>	3 110	GAV 602 010	<del>-9 120</del>	5 110	

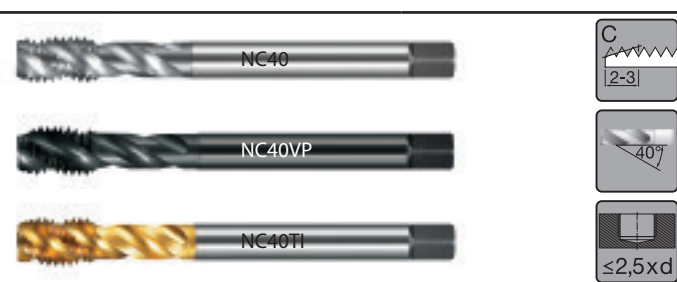
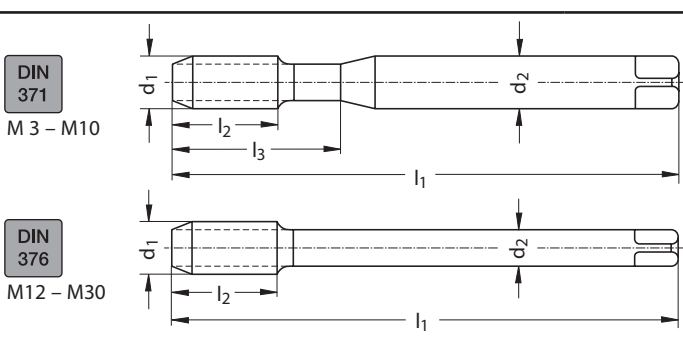

Rozměry										NC40			NC40VP			NC40TI		
d <sub>1</sub>	P	l <sub>1</sub>	l <sub>2</sub>	l <sub>3</sub>	d <sub>2</sub>	□	z	∅	Obj. číslo	Kč Set*	Kč Set*	Obj. číslo	Kč Set*	Kč Set*	Obj. číslo	Kč Set*	Kč Set*	
M 3	0,5	56	5	18	3,5	2,7	3	2,5	GAV 600 100	<del>-2 745</del>	1 540	GAV 601 100	<del>-2 745</del>	1 540	GAV 602 100	<del>-4 590</del>	2 580	
M 4	0,7	63	7	21	4,5	3,4	3	3,3	GAV 600 102	<del>-2 745</del>	1 540	GAV 601 102	<del>-2 745</del>	1 540	GAV 602 102	<del>-4 590</del>	2 580	
M 5	0,8	70	8	25	6	4,9	3	4,2	GAV 600 103	<del>-2 754</del>	1 540	GAV 601 103	<del>-2 754</del>	1 540	GAV 602 103	<del>-4 590</del>	2 580	
M 6	1	80	10	30	6	4,9	3	5	GAV 600 104	<del>-2 754</del>	1 540	GAV 601 104	<del>-2 754</del>	1 540	GAV 602 104	<del>-4 590</del>	2 580	
M 8	1,25	90	13	35	8	6,2	3	6,8	GAV 600 106	<del>-3 700</del>	2 080	GAV 601 106	<del>-3 700</del>	2 080	GAV 602 106	<del>-5 740</del>	3 290	
M 10	1,5	100	15	39	10	8	3	8,5	GAV 600 108	<del>-4 400</del>	2 470	GAV 601 108	<del>-4 400</del>	2 470	GAV 602 108	<del>-7 205</del>	4 110	
M 12	1,75	110	18	0	9	7	3	10,2	GAV 600 110	<del>-5 865</del>	3 290	GAV 601 110	<del>-5 740</del>	3 290	GAV 602 110	<del>-9 435</del>	5 400	

\* cena uvedena v Kč bez DPH za Set = 10 kusů závitníků stejného rozměru

VarioTool s.r.o. • Domažlická 39/210 • CZ-318 00 • Plzeň  
tel.: (+420) 371 120 072 • info@variotool.cz • www.variotool.cz

Platnost akce do 31. 7. 2025

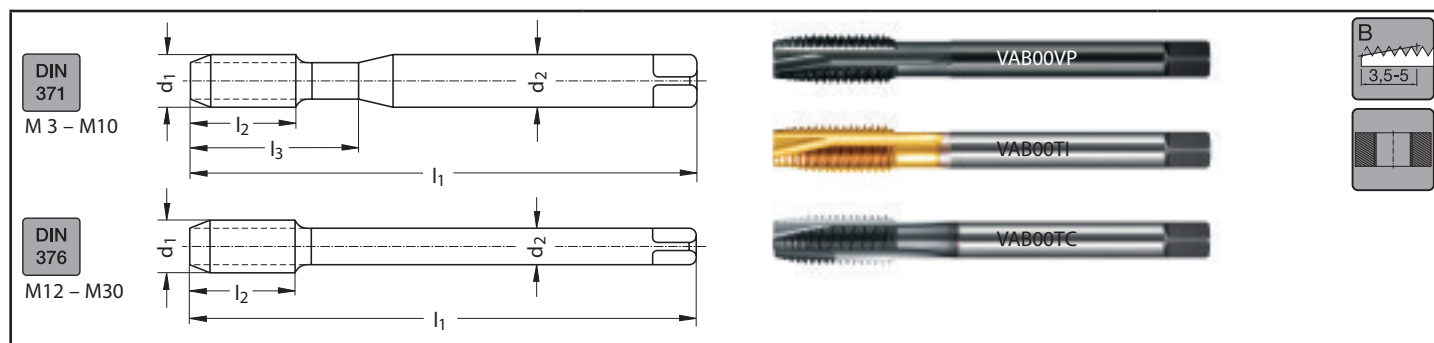

Rozměry										VAB00VP			VAB00TI			VAB00TC		
d <sub>1</sub>	P	l <sub>1</sub>	l <sub>2</sub>	l <sub>3</sub>	d <sub>2</sub>	□	z	∅		Obj. číslo	Kč Set*	Kč Set*	Obj. číslo	Kč Set*	Kč Set*	Obj. číslo	Kč Set*	Kč Set*
M 3	0,5	56	9	18	3,5	2,7	3	2,5		GAV 601 020	<del>2 870</del>	1 610	GAV 602 020	<del>4 720</del>	2 650	GAV 603 020	<del>5 040</del>	2 830
M 4	0,7	63	12	21	4,5	3,4	3	3,3		GAV 601 022	<del>2 870</del>	1 610	GAV 602 022	<del>4 720</del>	2 650	GAV 603 022	<del>5 040</del>	2 830
M 5	0,8	70	13	25	6	4,9	3	4,2		GAV 601 023	<del>2 870</del>	1 610	GAV 602 023	<del>4 720</del>	2 650	GAV 603 023	<del>5 040</del>	2 830
M 6	1	80	15	30	6	4,9	3	5		GAV 601 024	<del>2 870</del>	1 610	GAV 602 024	<del>4 720</del>	2 650	GAV 603 024	<del>5 040</del>	2 830
M 8	1,25	90	18	35	8	6,2	3	6,8		GAV 601 026	<del>3 890</del>	2 180	GAV 602 026	<del>6 060</del>	3 400	GAV 603 026	<del>6 315</del>	3 540
M 10	1,5	100	20	39	10	8	3	8,5		GAV 601 028	<del>4 590</del>	2 580	GAV 602 028	<del>7 590</del>	4 250	GAV 603 028	<del>7 780</del>	4 360
M 12	1,75	110	23	0	9	7	3	10,2		GAV 601 030	<del>6 060</del>	3 400	GAV 602 030	<del>9 630</del>	5 400	GAV 603 030	<del>9 885</del>	5 540

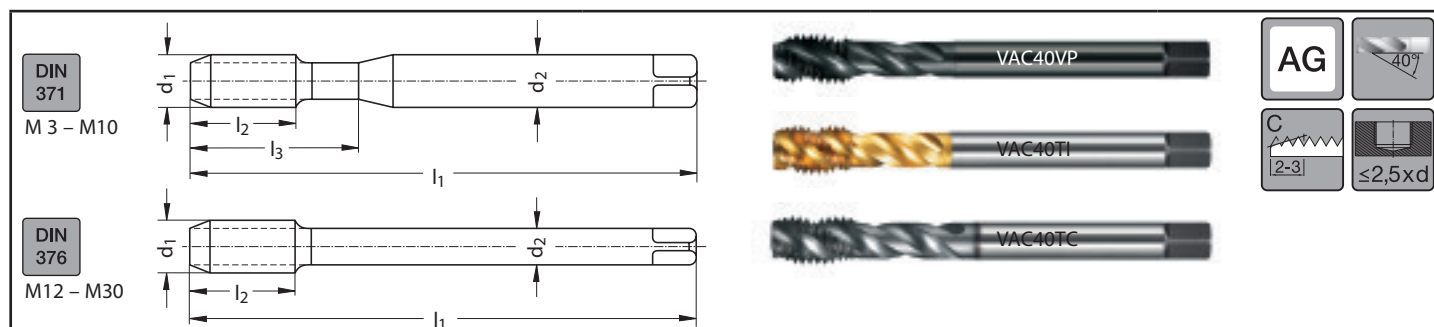

Rozměry										VAC40VP			VAC40TI			VAC40TC		
d <sub>1</sub>	P	l <sub>1</sub>	l <sub>2</sub>	l <sub>3</sub>	d <sub>2</sub>	□	z	∅		Obj. číslo	Kč Set*	Kč Set*	Obj. číslo	Kč Set*	Kč Set*	Obj. číslo	Kč Set*	Kč Set*
M 3	0,5	56	5	18	3,5	2,7	3	2,5		GAV 601 120	<del>3 060</del>	1 720	GAV 602 120	<del>4 785</del>	2 680	GAV 603 120	<del>5 100</del>	2 860
M 4	0,7	63	7	21	4,5	3,4	3	3,3		GAV 601 122	<del>3 060</del>	1 720	GAV 602 122	<del>4 785</del>	2 680	GAV 603 122	<del>5 100</del>	2 860
M 5	0,8	70	8	25	6	4,9	3	4,2		GAV 601 123	<del>3 190</del>	1 790	GAV 602 123	<del>5 040</del>	2 830	GAV 603 123	<del>5 165</del>	2 900
M 6	1	80	10	30	6	4,9	3	5		GAV 601 124	<del>3 190</del>	1 790	GAV 602 124	<del>5 040</del>	2 830	GAV 603 124	<del>5 165</del>	2 900
M 8	1,25	90	13	35	8	6,2	3	6,8		GAV 601 126	<del>4 020</del>	2 250	GAV 602 126	<del>6 185</del>	3 470	GAV 603 126	<del>6 505</del>	3 650
M 10	1,5	100	15	39	10	8	3	8,5		GAV 601 128	<del>4 655</del>	2 610	GAV 602 128	<del>7 650</del>	4 290	GAV 603 128	<del>7 845</del>	4 400
M 12	1,75	110	18	0	9	7	3	10,2		GAV 601 130	<del>6 185</del>	3 470	GAV 602 130	<del>9 755</del>	5 470	GAV 603 130	<del>10 075</del>	5 650

\* cena uvedena v Kč bez DPH za Set = 10 kusů závitníků stejného rozměru



pro dobře obrobitelné materiály do pevnosti 800 N/mm<sup>2</sup>



pro materiály s vyšší pevností a pro nerezové oceli



tvar spirálové drážky se zúžením průměru zlepšujícím odvod třísek, snižujícím vylamování u posledních závitů závitníku a snižujícím krouticí moment při zpětném pohybu závitníku